

QUANTUM

LITESTREAM XF LTD RQ



OWNER'S MANUAL

NOTE: IMPORTANT CHANGES REGARDING THE TRANSPORT OF WHEELCHAIRS ON PAGE 11.

Pride[®]
Mobility Products Company
www.pridemobility.com

380 Vansickle Road Unit 350 St. Catharines, Ontario L2R 6P7 1-888-570-1113

SAFETY GUIDELINES



WARNING! A Quantum Rehab Provider or a qualified technician must perform the initial setup of this wheelchair and must perform all of the procedures in this manual.

The symbols below are used throughout this owner's manual and on the wheelchair to identify warnings and important information. It is very important for you to read them and understand them completely.



WARNING! Indicates a potentially hazardous condition/situation. Failure to follow designated procedures can cause either personal injury, component damage, or malfunction. On the product, this icon is represented as a black symbol on a yellow triangle with a black border.



MANDATORY! These actions should be performed as specified. Failure to perform mandatory actions can cause personal injury and/or equipment damage. On the product, this icon is represented as a white symbol on a blue dot with a white border.



PROHIBITED! These actions are prohibited. These actions should not be performed at any time or in any circumstances. Performing a prohibited action can cause personal injury and/or equipment damage. On the product, this icon is represented as a black symbol with a red circle and red slash.

INTENDED USE

The intended use of the Pride Mobility Products device is to provide mobility to persons limited to a seated position that have the capability of operating a wheelchair.

Quick Reference Information

Quantum Rehab Provider: _____

Address: _____

Phone Number: _____

Purchase Date: _____

NOTE: This owner's manual is compiled from the latest specifications and product information available at the time of publication. We reserve the right to make changes as they become necessary. Any changes to our products may cause slight variations between the illustrations and explanations in this manual and the product you have purchased. The latest/current version of this manual is available on our website.



Copyright © 2012

Pride Mobility Products Company

INFMANU4240/Rev A/April 2012

CONTENTS

| | |
|--------------------------------|----|
| I. INTRODUCTION | 4 |
| II. SAFETY | 5 |
| III. YOUR WHEELCHAIR | 14 |
| IV. COMFORT ADJUSTMENTS | 17 |
| V. CARE AND MAINTENANCE | 29 |
| VI. WARRANTY | 33 |

I. INTRODUCTION

SAFETY

WELCOME to Quantum Rehab, a division of Pride Mobility Products (Pride). The wheelchair you have purchased combines state-of-the-art components with **safety**, comfort, and styling in mind. We are confident that these design features will provide you with the conveniences you expect during your daily activities. Once you understand how to **safely** operate and care for your wheelchair, it should give you years of trouble-free operation and service.

Read and follow all instructions, warnings, and notes in this manual before attempting to operate your wheelchair for the first time. You must also read all instructions, warnings, and notes contained in any supplemental instructional booklets that accompanied your wheelchair before initial operation. Your **safety** depends upon you, as well as your provider, caretaker, or healthcare professional in using good judgment.

If there is any information in this manual which you do not understand, or if you require additional assistance for setup or operation, please contact your Quantum Rehab Provider. **Failure to follow the instructions in this manual and those located on your wheelchair can lead to personal injury and/or damage to the wheelchair, including voiding the warranty.**

PURCHASER'S AGREEMENT

By accepting delivery of this product, you promise that you will not change, alter, or modify this product or remove or render inoperable or unsafe any guards, shields, or other safety features of this product; fail, refuse, or neglect to install any retrofit kits from time to time provided by Pride to enhance or preserve the safe use of this product.

SHIPPING AND DELIVERY

Before using your wheelchair, make sure your delivery is complete as some components may be individually packaged. If you do not receive a complete delivery, please contact your Quantum Rehab Provider immediately. Where damage has occurred during transport, either to the packaging or content, please contact the delivery company responsible.

INFORMATION EXCHANGE

We want to hear your questions, comments, and suggestions about this manual. We would also like to hear about the safety and reliability of your new wheelchair, and about the service you received from your Quantum Rehab Provider. Please notify us of any change of address, so we can keep you apprised of important information about safety, new products, and new options that can increase your ability to use and enjoy your wheelchair. Please feel free to contact us at the following address:

Pride Mobility Products Company
380 Vansickle Road Unit 350
St. Catharines, Ontario L2R 6P7
1-888-570-1113

NOTE: *If you ever lose or misplace your product registration card or your copy of this manual, contact us and we will be glad to send you a new one immediately.*

II. SAFETY

PRODUCT SAFETY SYMBOLS

The symbols below are used on the wheelchair to identify warnings, mandatory actions, and prohibited actions. It is very important for you to read and understand them completely.



Read and follow the information in the owner's manual.



Maximum seating weight.



Keep your hands away from the tires when driving. Be aware that loose fitting clothing can become caught in drive tires.



Avoid exposure to rain, snow, ice, salt, or standing water whenever possible. Maintain and store in a clean and dry condition.



Pinch/Crush points created during assembly.



Disposal and recycling - Contact your Quantum Rehab Provider for information on proper disposal and recycling of your Pride product and its packaging.



II. SAFETY



Do not allow the wheelchair to roll freely on a decline.



Do not allow the wheelchair to roll freely on an incline.

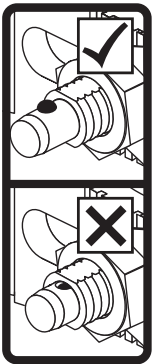

Ensure the ball detents on the quick-release axles snap into place and are fully visible after drive wheel installation.



Indicates wheelchair securement points.



Indicates that wheelchair, with similarly labeled seating system, conforms to ANSI/RESNA WC/Vol. 4, Section 19 for transport of an occupied power chair in a motor vehicle.

II. SAFETY

GENERAL GUIDELINES



MANDATORY! Do not operate your new wheelchair for the first time without completely reading and understanding this owner's manual.

Your wheelchair is a state-of-the-art life-enhancement device designed to increase mobility. Pride provides an extensive variety of products to best fit the individual needs of the wheelchair user. Please be aware that the final selection and purchasing decision regarding the type of wheelchair to be used is the responsibility of the wheelchair user, who is capable of making such a decision, and his/her healthcare professional (i.e., medical doctor, physical therapist, etc.).

The contents of this manual are based on the expectation that a mobility device expert has properly fitted the wheelchair to the user and has assisted the prescribing healthcare professional and/or the Quantum Rehab Provider in the instruction process for the use of the product.

There are certain situations, including some medical conditions, where the wheelchair user will need to practice operating the wheelchair in the presence of a trained attendant. A trained attendant can be defined as a family member or care professional specially trained in assisting a wheelchair user in various daily living activities.

As you begin using your wheelchair during daily activities, you will probably encounter situations in which you will need some practice. Simply take your time and you will soon be in full and confident control as you maneuver through doorways, on and off of elevators, up and down ramps, and over moderate terrain.

Below are some precautions, tips, and other safety considerations that will help you become accustomed to operating your wheelchair safely.

Modifications

Pride has designed and engineered your wheelchair to provide maximum mobility and utility. A wide range of accessories is available from your Quantum Rehab Provider to further customize your wheelchair to better suit your needs and/or preferences. However, under no circumstances should you modify, add, remove, or disable any feature, part, or function of your wheelchair.



WARNING! Do not modify your wheelchair in any way not authorized by Pride. Do not use accessories if they have not been tested or approved for Pride products.

Pre-Ride Safety Check

Get to know the feel of your wheelchair and its capabilities. Pride recommends that you perform a safety check before each use to make sure your wheelchair operates smoothly and safely. Before riding, you should be trained in the safe use of this wheelchair by your authorized Pride Provider.

Perform the following inspections prior to using your wheelchair:

- Check for proper tire inflation. Maintain but do not exceed the psi/bar/kPa air pressure rating indicated on each tire if equipped with pneumatic tires.
- Check the brakes. See V. "Care and Maintenance."

NOTE: If you discover a problem, contact your Quantum Rehab Provider for assistance.

II. SAFETY

Weight Limitations

Your wheelchair is rated for a maximum weight capacity. Please refer to the specifications table for this limit. Keep in mind that the maximum weight capacity includes the combined weight of the user and any accessories mounted to the wheelchair.



MANDATORY! Stay within the specified weight capacity of your wheelchair. Exceeding the weight capacity voids your warranty. Pride will not be held responsible for injuries and/or property damage resulting from failure to observe weight limitations.

WARNING! Do not carry passengers on your wheelchair. Carrying passengers on your wheelchair may affect the center of gravity, resulting in a tip or a fall.



WARNING! The rear flap is for pocket items such as cell phones, keys, and papers. Avoid storing sharp objects in the rear flap. There are no other storage areas on your wheelchair.

WARNING! Do not carry heavy baggage weighing more than 4.5 kg (10 lbs.) on the back of the wheelchair. Carrying or tying baggage in excess of 4.5 kg (10 lbs.) on the back of the wheelchair may affect the center of gravity, resulting in a tip or a fall.

Tire Inflation

If your wheelchair is equipped with pneumatic tires, you should check or have the air pressure checked regularly. Proper inflation pressures will prolong the life of your tires and help ensure the smooth operation of your wheelchair.



WARNING! It is important that the psi/bar/kPa air pressure rating indicated on the tire be maintained in pneumatic tires at all times. Do not underinflate or overinflate your tires. Low pressure may result in loss of control, and overinflated tires may burst. Failure to maintain the psi/bar/kPa air pressure rating indicated on the pneumatic tires at all times may result in tire and/or wheel failure.

WARNING! Inflate your wheelchair drive tires from a regulated air source with an available pressure gauge. Inflating your tires from an unregulated air source could overinflate them, resulting in a burst tire.

NOTE: If the tire on your wheelchair lists the psi rating only, use the following conversion formulas to find the bar or kPa rating: $bar = psi \times 0.06895$; $kPa = psi \times 6.89476$.

Incline Information

More and more buildings have ramps with specified degrees of inclination, designed for easy and safe access. Some ramps may have turning switchbacks (180-degree turns) that require you to have good cornering skills on your wheelchair.

- Proceed with extreme caution as you approach the downgrade of a ramp or other incline.
- Take wide swings with your wheelchair's front wheels around any tight corners. If you do that, the wheelchair's rear wheels will follow a wide arc, not cut the corner short, and not bump into or get hung up on any railing corners.
- When driving down a ramp, proceed slowly to ensure a safely controlled descent.
- Avoid sudden stops and starts.

When climbing an incline, try to keep your wheelchair moving. If you must stop, start up again slowly and then accelerate cautiously. When driving down an incline, proceed slowly and drive in the forward direction only. If your wheelchair starts to move down the incline faster than you anticipated or desired, bring it to a complete stop using both hands, then proceed slowly to ensure a safely controlled descent.



WARNING! When on any sort of an incline or decline, never allow the wheelchair to roll freely while seated on it.



WARNING! When climbing an incline, do not zigzag or drive at an angle up the face of the incline. Drive your wheelchair straight up the incline. This greatly reduces the possibility of a tip or a fall. Always exercise extreme caution when negotiating an incline.

II. SAFETY

WARNING! You should not travel up or down a potentially hazardous incline (i.e., areas covered with snow, ice, cut grass, or wet leaves).

WARNING! Never travel down an incline backward. Doing so may cause the wheelchair to tip. Always exercise extreme caution when negotiating an incline.



WARNING! If your wheelchair is equipped with an optional carry bag mounted to the seatback, do not overload the bag or exceed the maximum load rating of the bag. Doing so could cause instability in your wheelchair when negotiating inclines, causing it to tip.

WARNING! Pride recommends being extremely vigilant and careful when you cross a slope greater than 5 degrees because depending on your skills, the configuration, and the settings of your wheelchair, it could tip over backward and cause serious injuries. Please follow the recommendations of your health care professional about your ability to cross a slope greater than 5° independently or with assistance.

Pride recommends that the maximum slope of an incline you attempt to safely ascend or descend on your wheelchair does not exceed 8.7% (5°). See figure 1.



WARNING! Any attempt to climb or descend a slope steeper than 8.7% (5°) may put your wheelchair in an unstable position and cause it to tip.

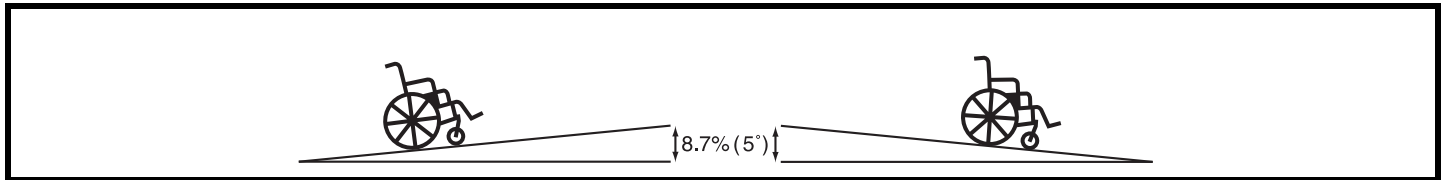

Figure 1. Recommended Maximum Safe Slope (Ascending and Descending)

Braking Information

To stop the wheelchair, apply pressure to both handrims until the wheelchair comes to a complete stop.

Manual Wheel Locks

Your wheelchair is equipped with two manual wheel locks; one mounted near (or directly in front of) each drive wheel. The manual wheel locks help prevent your wheelchair from moving when parked. After you bring your wheelchair to a complete stop, engage both manual wheel locks. There are two types of manual wheel locks available on your wheelchair: push-to-lock and pull-to-lock. If you have any questions about the operation of your manual wheel locks, contact your Quantum Rehab Provider.

NOTE: Pride does not recommend that you remain parked on an incline for a long period of time as your wheelchair may slide or the the manual wheel lock may become disengaged after extended use.



WARNING! Do not attempt to use either manual wheel lock lever to stop your wheelchair.

WARNING! Pride does not recommend that you remain parked on an incline for a long period of time.



WARNING! Use care when operating wheel locks. Possible pinch point created during operation.

Cornering Information

While your wheelchair is equipped with front caster wheels, excessively high cornering speeds can still create the possibility of tipping. Factors which affect the possibility of tipping include, but are not limited to: cornering speed, steering angle (how sharply you are turning), uneven road surfaces, inclined road surfaces, riding from an area of low traction to an area of high traction (such as passing from a grassy area to a paved area—especially at high speed while turning), and abrupt directional changes. High cornering speeds are not recommended. If you feel that you may tip over in a corner, reduce your speed and steering angle (i.e., lessen the sharpness of the turn) to prevent your wheelchair from tipping.

II. SAFETY



WARNING! When cornering sharply, reduce your speed and maintain a stable center of gravity. This greatly reduces the possibility of a tip or fall.

Public Streets and Roadways



WARNING! You should not operate your wheelchair on public streets and roadways. Be aware that it may be difficult for traffic to see you when you are seated on your wheelchair. Obey all local pedestrian traffic rules. Wait until your path is clear of traffic, and then proceed with extreme caution.

Outdoor Driving Surfaces

Your wheelchair is designed to provide optimum stability under normal driving conditions—dry, level surfaces composed of concrete, blacktop, or asphalt. However, Pride recognizes that there will be times when you will encounter other surface types. For this reason, your wheelchair is designed to perform admirably on packed soil, grass, and gravel. Feel free to use your wheelchair safely on lawns and in park areas.

- Avoid driving on uneven terrain and/or soft surfaces.
- Avoid tall grass that can entangle the drive wheels or caster wheels.
- Avoid loosely packed gravel and sand.
- Avoid uneven surfaces.
- Do not use your wheelchair in fresh or salt water.
- Do not use your wheelchair at the edge of a stream, lake, or ocean.
- If you feel unsure about a driving surface, avoid that surface.

Inclement Weather Precautions

Exposure of your wheelchair to inclement weather conditions should be avoided whenever possible. If suddenly caught up in rain, snow, severe cold or heat while operating your wheelchair, proceed to shelter at the earliest opportunity. Thoroughly dry your wheelchair before storing or operating your wheelchair.



PROHIBITED! Operating in rain, snow, salt, mist/spray conditions, and on icy/slippery surfaces can have an adverse effect on your wheelchair. Maintain and store your wheelchair in a dry and clean condition.



WARNING! Prolonged exposure to hot or cold conditions may affect the temperature of upholstered and non-upholstered items on the wheelchair, possibly resulting in skin irritation. Exercise caution when using the wheelchair in extremely hot or cold conditions or when exposing your wheelchair to direct sunlight for prolonged periods of time.

Stationary Obstacles (Steps, Curbs, etc.)

Proceed with extreme caution when driving near raised surfaces, unprotected ledges, and/or drop-offs (curbs, porches, stairs, etc.). Be sure your wheelchair is traveling perpendicular to any curb you may be required to navigate. See figure 2.



WARNING! Even though your wheelchair may be capable of handling greater obstacles, Pride recommends that you do not attempt to negotiate a curb that has a height greater than 5 cm (2 in.). Doing so could cause instability in your wheelchair.

WARNING! Do not attempt to have your wheelchair proceed backward down any step, curb, or other obstacle. This may cause the wheelchair to tip.

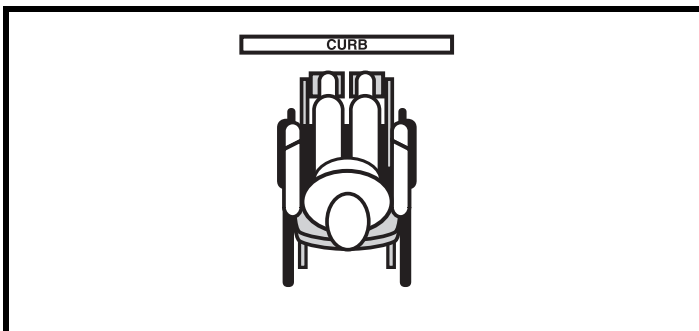

Figure 2. Correct Curb Approach

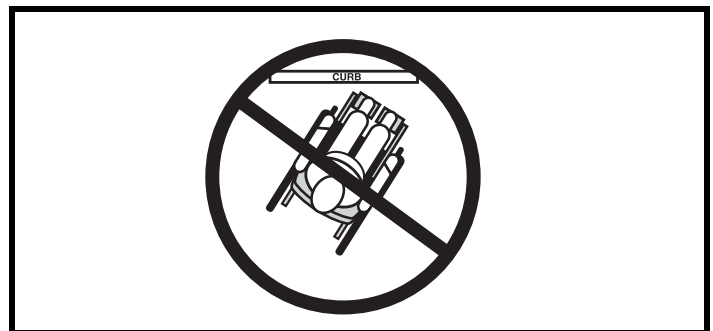

Figure 3. Incorrect Curb Approach

II. SAFETY

Stairs and Escalators

Wheelchairs are not designed to travel up or down stairs or escalators. Always use an elevator.



WARNING! Never use your wheelchair to negotiate steps or escalators.

Doors

- Determine if the door opens toward or away from you.
- Drive your wheelchair gently and slowly forward to push the door open. Or drive your wheelchair gently and slowly backward to pull the door open.

Elevators

Modern elevators have a door edge safety mechanism that, when pushed, reopens the elevator door(s).

- If you are in the doorway of an elevator when the door(s) begin to close, push on the rubber door edge or allow the rubber door edge to contact the wheelchair and the door will reopen.
- Use care that pocketbooks, packages, or wheelchair accessories do not become caught in elevator doors.

Lift Systems/Elevation Products

If you will be transporting your wheelchair during travel, you may find it necessary to use a vehicle-mounted lift system or elevation product to aid in transportation. Pride recommends that you closely review the warnings, instructions, specifications, and safety information set forth by the manufacturer of the lift/elevation product before using that product.



WARNING! Not all lift systems/elevation products are rated for use with an occupied mobility device. Pride recommends that you do not remain seated in your wheelchair when it is being used in connection with any type of lift system/elevation product unless:

- That product is rated for occupied use by the manufacturer.
- You are able to occupy your mobility device in strict conformity with the warnings, instructions, specifications, and safety guidelines set forth by the manufacturer.

Transport Vehicles in Quebec, Canada

A person can travel in a secure manner while seated in a Pride wheelchair onboard a public vehicle adapted for transportation of handicapped persons provided that the wheelchair securement system and the system of withholding the person is in accordance with the applicable normes in force as stipulated in the regulation on road vehicles adapted to the transportation of handicapped persons, D. 1058-93, a. 1-72.

Pride Mobility Products cannot be held responsible for the usage of devices not in accordance with this regulation. It is the same for misuse of restraint by others, as well as unauthorized modifications to the wheelchair, the support system of the body, seat, or cushion.



WARNING! Always be sure your wheelchair is properly secured when it is being transported.

The wheelchair may be equipped with four (4) tie-down points for the purpose of securing the unoccupied wheelchair during motor vehicle transport. Each tie-down point is clearly labeled for this purpose.

- Do not modify or remove the tie-down points provided as original equipment on the wheelchair.
- Conform to the requirements in the Quebec/Canada decree 1058-93, July 21, 1993, governing the transport of people with reduced mobility.

II. SAFETY

Positioning Belts

Your Quantum Rehab Provider, therapist(s), and other healthcare professionals are responsible for determining your requirement for a positioning belt in order to operate your wheelchair safely. Typically, the positioning belt is not designed for use as a restraining device in a motor vehicle. You should be properly belted into seats approved by the vehicle manufacturer with your wheelchair properly stowed for vehicle transport.

WARNING! If you require a positioning belt to safely operate your wheelchair, make sure it is fastened securely in order to reduce the possibility of a fall from the wheelchair.



WARNING! The positioning belt is not designed for use as a seat belt in a motor vehicle. Nor is your wheelchair suitable for use as a seat in any vehicle. Anyone traveling in a vehicle should be properly belted into seats approved by the vehicle manufacturer.

Removable Parts

WARNING! Do not attempt to lift or move a wheelchair by any of its removable parts, including the armrests, seat, and front riggings. Do not attempt to pick up the wheelchair while the seat is occupied. Pride recommends use of only solid, non-removable frame components to lift or move your wheelchair.



Reaching and Bending

Never reach, lean, or bend while driving your wheelchair. If it is absolutely necessary to reach, lean, or bend while seated on your wheelchair, it is important to maintain a stable center of gravity and keep the wheelchair from tipping. Pride recommends that the wheelchair user determine his/her personal limitations and practice bending and reaching in the presence of a qualified healthcare professional.



WARNING! Do not bend, lean, or reach for objects if you have to pick them up from the floor by reaching down between your knees or if you have to reach over the back of the seat. Movements such as these may change your center of gravity and the weight distribution of the wheelchair. This may cause your wheelchair to tip.



WARNING! Keep your hands away from the tires when driving. Be aware that loose fitting clothing can become caught in drive tires.

Transfers

Transferring onto and off of your wheelchair requires a good sense of balance. Always have an attendant or healthcare professional present while learning to properly transfer yourself.

- Engage the caster pin lock, if equipped. See III. “Your Wheelchair.”

NOTE: If your wheelchair is equipped with a caster pin lock, be sure to disengage the caster pin lock before operating your wheelchair. See III. “Your Wheelchair.”

- Ensure both wheel locks on your wheelchair are engaged. See III. “Your Wheelchair.”
- If necessary, remove or flip up one or both armrests. See IV. “Comfort Adjustments.”

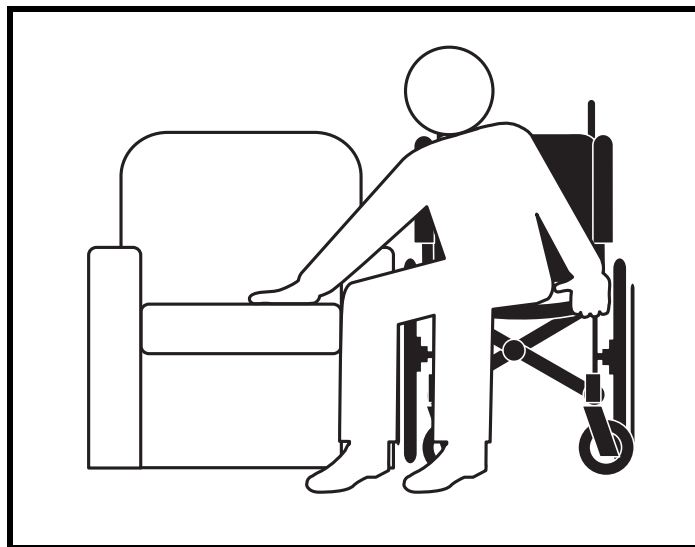

Figure 4. Ideal Transfer Position

II. SAFETY

- If your wheelchair is not equipped with a caster pin lock, turn both caster wheels toward the transfer destination to improve wheelchair stability during transfer.
- Move the leg rests aside; this will help to keep your feet from getting caught on the front rigging during the transfer.
- Reduce the distance between your wheelchair and the object you are transferring onto.

WARNING! Before transferring, position yourself as far back as possible in the wheelchair seat to prevent the wheelchair from tipping forward during transfer.

WARNING! Avoid putting all of your weight on the wheelchair armrests and do not use the armrests for weight bearing purposes, such as transfers. Such use may cause the wheelchair to tip, resulting in a fall from the wheelchair and personal injury.



WARNING! Avoid putting all of your weight on the manual wheel locks and do not use the manual wheel locks for weight bearing purposes, such as transfers. Such use may cause equipment damage or personal injury.

WARNING! Avoid putting all of your weight on the front riggings. Such use may cause the wheelchair to tip.

WARNING! Ensure legs, hands, and clothing are clear of the scissor-style wheel lock levers when attempting to transfer.

Prescription Drugs/Physical Limitations

Users must exercise care and common sense when operating a wheelchair. This includes awareness of safety issues when taking prescribed or over-the-counter drugs or when the user has specific physical limitations.



WARNING! Consult your physician if you are taking prescribed or over-the-counter medication or if you have certain physical limitations. Some medications and limitations may impair your ability to operate your wheelchair in a safe manner.

Alcohol/Smoking

The wheelchair user must exercise care and common sense when operating his/her wheelchair. This includes awareness of safety issues while under the influence of alcohol or while smoking.

WARNING! Do not operate your wheelchair while you are under the influence of alcohol, as this may impair your ability to operate your wheelchair in a safe manner.



WARNING! Pride strongly recommends that you do not smoke cigarettes while seated in your wheelchair, although the wheelchair has passed the necessary testing requirements for cigarette smoking. You must adhere to the following safety guidelines if you decide to smoke cigarettes while seated in your wheelchair.

- Do not leave lit cigarettes unattended.
- Keep ashtrays a safe distance from the seat cushions.
- Always make sure cigarettes are completely extinguished before disposal.

Flammability Precautions

WARNING! Even though the plastics used on your wheelchair have been tested and have passed the applicable flammability standards, Pride recommends that you do not expose your wheelchair to open flames.



WARNING! Replace worn or damaged upholstery immediately to reduce the risk of fire hazard.

WARNING! Be aware that washing of upholstered items may reduce the resistance to flammability of the fabric.

III. YOUR WHEELCHAIR

THE LITESTREAM XF LTD RQ

The Litestream XF LTD RQ is a dual-purpose, rear-wheel drive wheelchair designed to operate both indoors and outdoors on smooth surfaces.

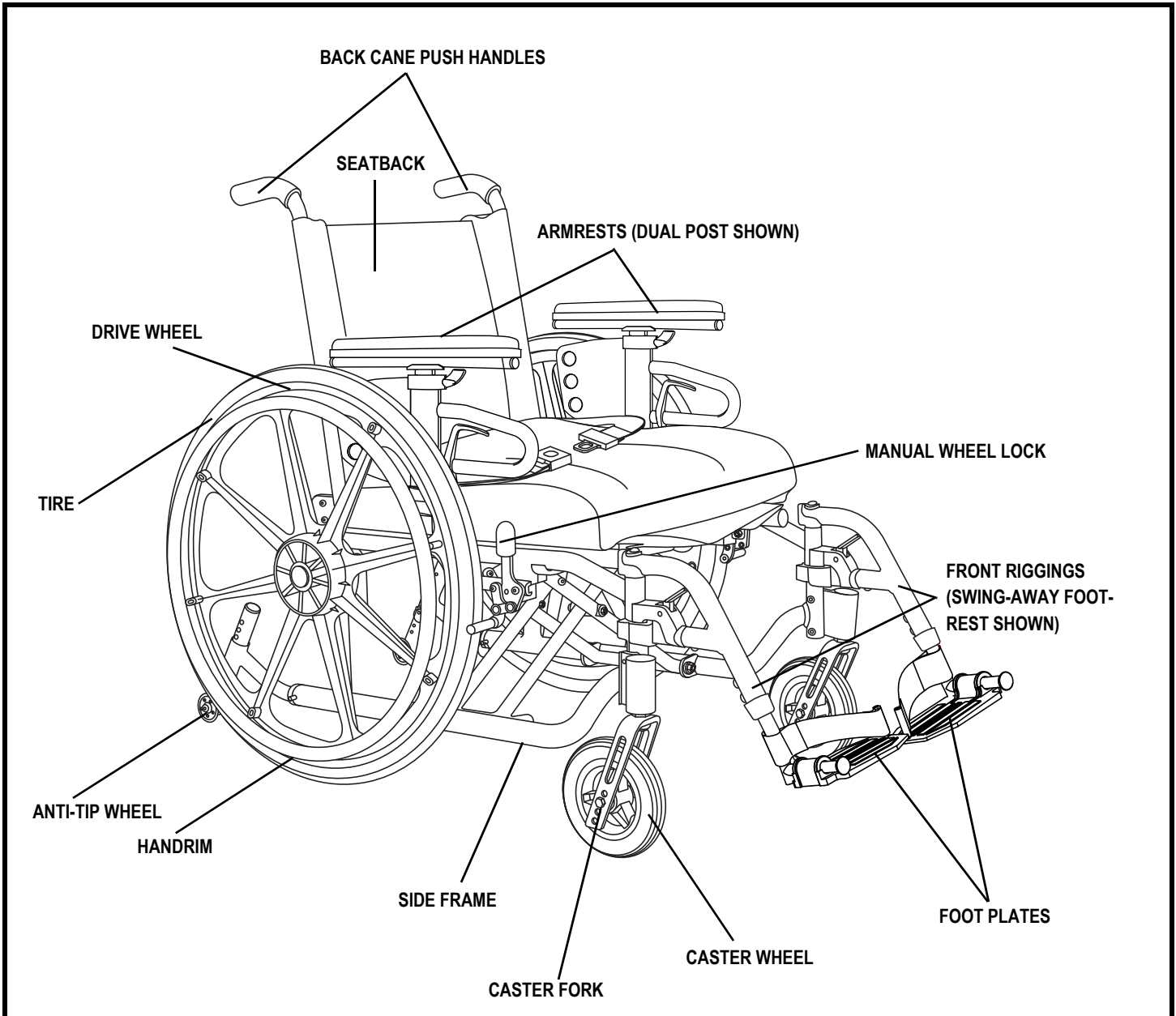

Figure 5. The Litestream XF LTD RQ Wheelchair

III. YOUR WHEELCHAIR

USING THE LITESTREAM XF LTD RQ

The Litestream XF LTD RQ is a manual wheelchair. Either an attendant pushes it, or you move it by gripping the handrims (see figure 5) and turning them in the desired direction of travel. You steer it by turning one wheel faster than the other. To stop the wheelchair, you apply pressure to both handrims until the wheelchair comes to a complete stop.

Unfolding

The Litestream XF LTD RQ is a folding wheelchair. Unfold it completely before sitting in it.

To unfold the Litestream XF LTD RQ:

1. Engage both manual wheel locks. See figure 6.



WARNING! Use care when operating the manual wheel locks. Possible pinch point created during operation.

2. Place the palms of your hands on each seat base rail. See figure 7.
3. Press down until the seat base rails are locked into place.

Folding

Folding the wheelchair makes it easier to carry and store. The folded width is 29.85 cm (11.75 in.).

To fold the Litestream XF LTD RQ:

1. Engage both manual wheel locks. See figure 6.
2. Flip up the foot plates (if applicable)
3. Hold the seat base by the center at the front and at the back. See figure 7.
4. Pull up on the strap until both wheels close together. See figure 8.

Transporting Your Litestream XF LTD RQ

The Litestream XF LTD RQ was designed to be folded and stored in a secure location, such as the trunk of a car, during motor vehicle transport.

To stow the Litestream XF LTD RQ:

1. Fold the Litestream XF LTD RQ.
2. With one hand, grab and squeeze together both back cane handles. See figure 9.
3. With the other hand, grab and squeeze together both seat base rails.

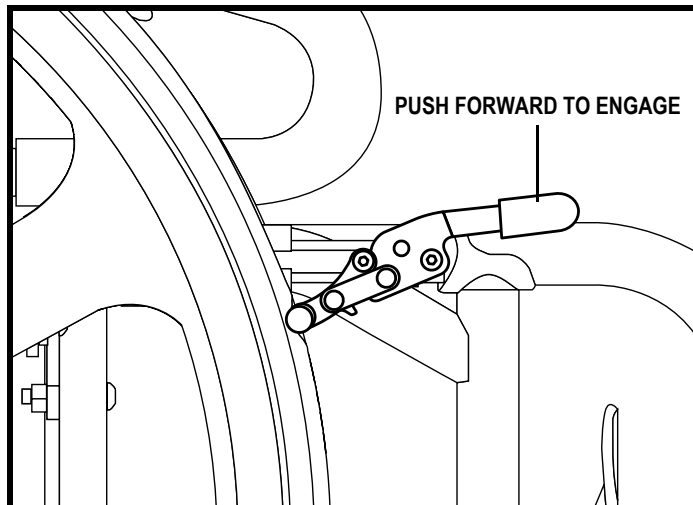

Figure 6. Right Manual Wheel Lock Engaged (Push-to-Lock Shown)

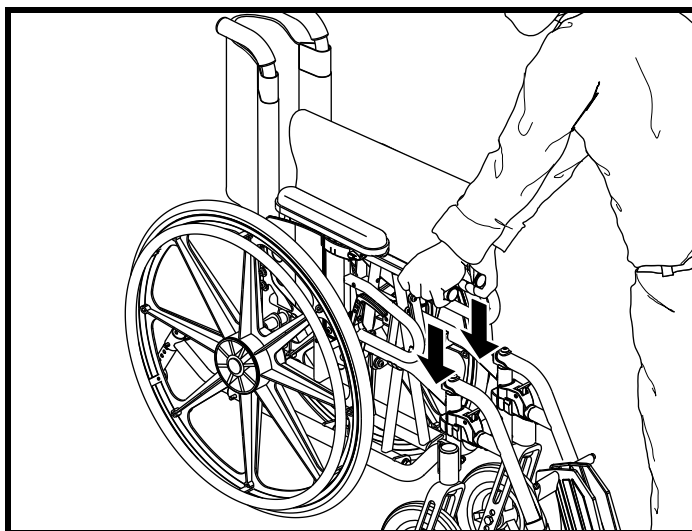

Figure 7. Unfolding the Litestream XF LTD RQ

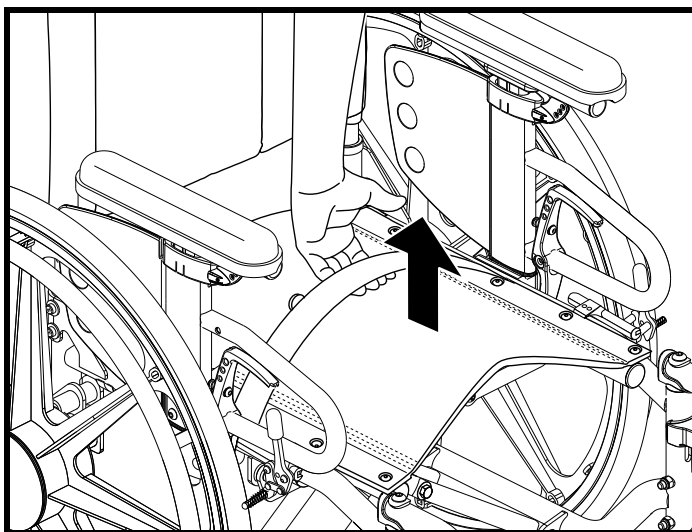

Figure 8. Folding the Litestream XF LTD RQ

III. YOUR WHEELCHAIR

NOTE: You can also remove the drive wheels to make the wheelchair more compact. See “Drive Wheel Adjustments.”



WARNING! If you remove the drive wheels, make sure the ball detents on the quick-release axles snap into place when reinstalling the wheel, if equipped. See “Drive Wheel Position.”

Optional Caster Pin Lock

If your wheelchair is equipped with a caster pin lock, you can lock the caster wheels in the forward position to aid in transferring. The caster pin lock should be engaged prior to transfer and disengaged prior to operating the wheelchair.

To operate the caster pin lock:

1. Rotate the lever so that the securement pin is not in the groove to engage the caster pin lock. See figure 11.
2. Rotate the lever so that the securement pin is securely in the groove to disengage the caster pin lock. See figure 11.

Wheelchair Securement Points

The wheelchair may be equipped with four (4) tie-down points for the purpose of securing the unoccupied wheelchair during motor vehicle transport. Each tie-down point is clearly labeled for this purpose.

To secure a wheelchair equipped with tie-down points:



WARNING! Always use the manufacturer-installed front and rear securement brackets supplied with the transit securement system. Do not modify the transit system securement brackets in any way. Do not modify your wheelchair in any way unless authorized by Pride.

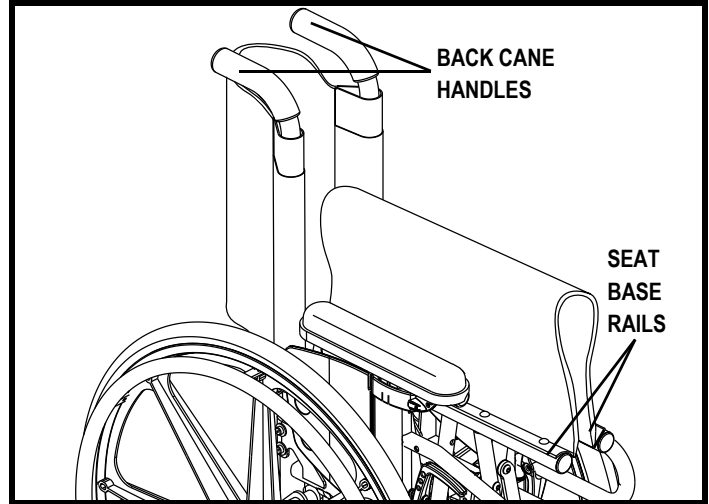

Figure 9. Lifting Points

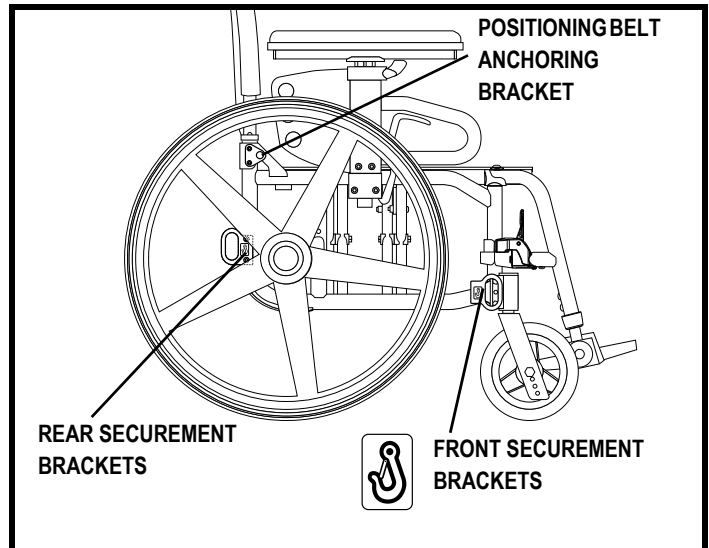

Figure 10. Securement Points

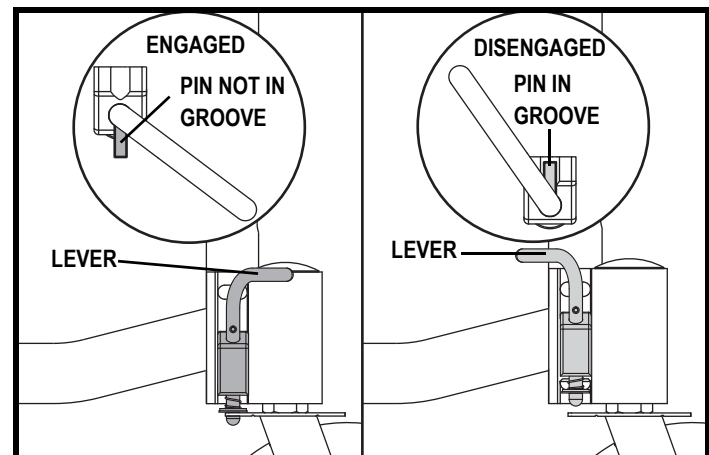

Figure 11. Caster Pin Lock Operation

III. YOUR WHEELCHAIR

To secure a wheelchair equipped with tie-down points:

- Always secure the wheelchair in a forward-facing position in the vehicle.
- Attach the four tie-down straps only to designated, labeled transit securement points indicated by anchor symbols on the wheelchair. See figures 10 and 12. Tighten the straps to sufficiently remove all slack.
- Never attach tie-downs to adjustable, moving, or removable parts of the wheelchair such as armrests, front riggings, and wheels.
- Position the anchor points for the rear tie-down straps directly behind the rear securement points on the wheelchair. The front tie-down straps should be anchored to floor points that are spaced wider than the wheelchair to provide increased stability. See figure 10.



MANDATORY! The wheelchair should be used as indicated in the manufacturer's instructions. If you have any questions about the proper use of your wheelchair, contact your Quantum Rehab Provider.

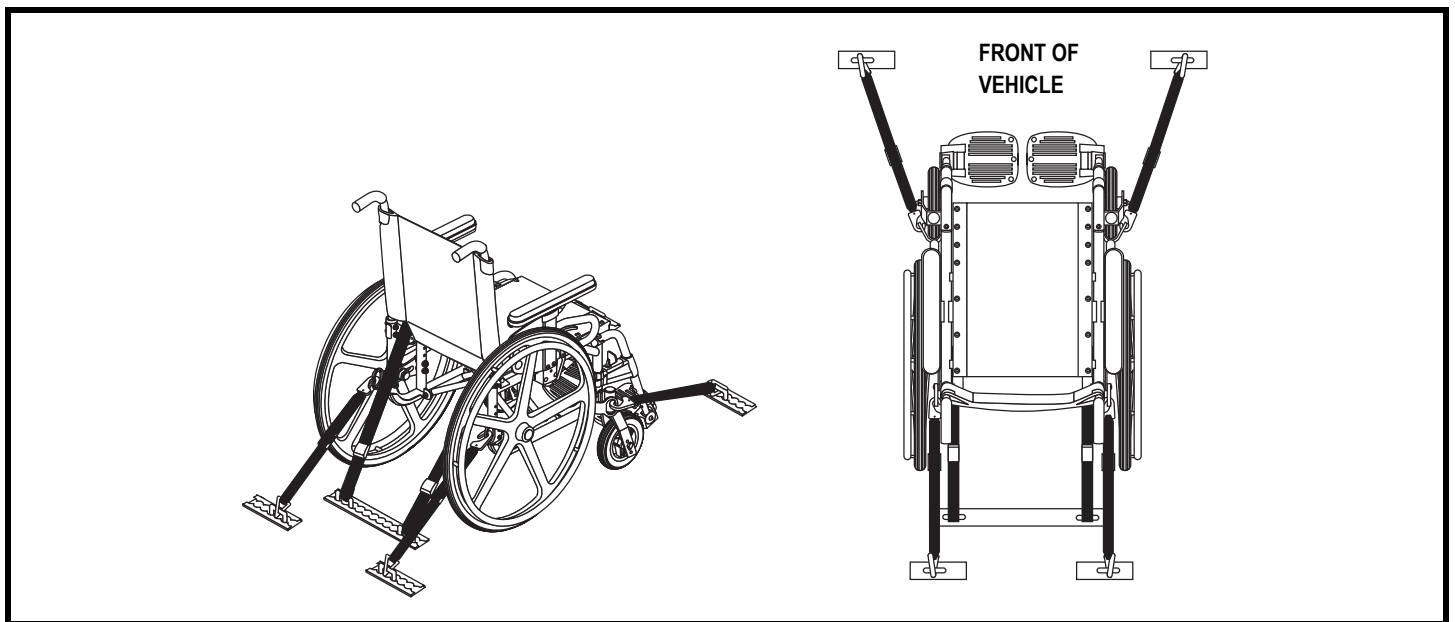

Figure 12. Securing the Wheelchair

IV. COMFORT ADJUSTMENTS

COMFORT ADJUSTMENTS

After becoming familiar with your wheelchair's operation, you may find the need to make some adjustments to increase your comfort such as drive wheel position, swing-away footrest length, elevating leg rest length and angle, calf pad height, depth, and angle, seatback height, armrest height, seat angle, wheel lock position, seat tension, and caster angle.

WARNING! The center of gravity of your wheelchair was factory set to a position that meets the needs of the demographic majority of users. Your Quantum Rehab Provider has evaluated your wheelchair and made any necessary adjustments to suit your specific requirements. Do not change your seating configuration without first contacting Pride Mobility Products or your Quantum Rehab Provider.



WARNING! Some wheelchair components are heavy. You may need assistance to lift or carry them. Please refer to the specifications table for specific component weights before you disassemble the wheelchair.

WARNING! Remove the occupant from the wheelchair before making any adjustments.

You may need the following to make comfort adjustments:

- 1/8-in. wrench
- 3/8-in. wrench
- 7/16-in. wrench
- 1/2-in. wrench
- 3/4-in. wrench

NOTE: Any nylon insert lock nut removed during the disassembly or adjustment of the wheelchair must be replaced with a new nut. Nylon insert lock nuts should not be reused as it may cause damage to the nylon insert, resulting in a less secure fit. Replacement nylon insert lock nuts are available through your Quantum Rehab Provider.

NOTE: It may be necessary to apply thread lock when reinstalling hardware.

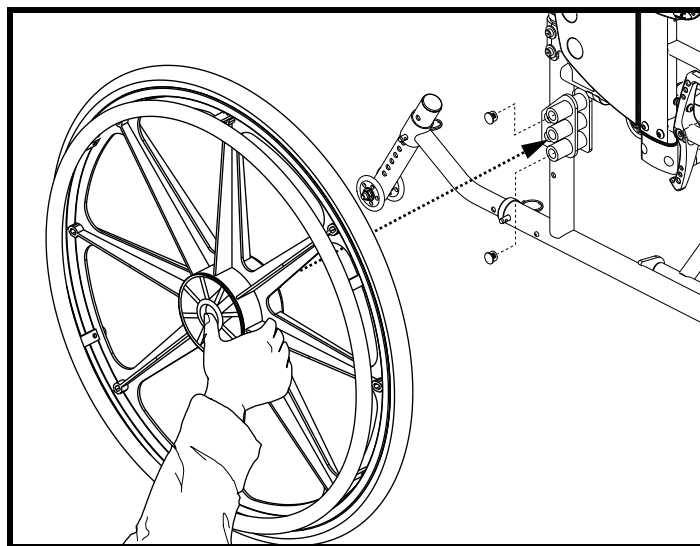

Figure 13. Drive Wheel Removal - Quick Release

Drive Wheel Adjustments

Each drive wheel is attached to the frame by an axle bracket. The location of the drive wheel center bolt and nut on the axle bracket determines the drive wheel position. The location of the axle bracket on the wheelchair frame determines the drive wheel height and can affect performance and center of gravity.

NOTE: If you change the drive wheel position, you may have to change the caster height and adjust the wheel lock. Consult your Quantum Rehab Provider.

WARNING! The more forward that you adjust your drive wheel, the more likely your wheelchair will tip over backward. Always make adjustments in small increments, and check the stability of your wheelchair with a Quantum Rehab Provider or with a spotter to prevent a tip over. We recommend that you use anti-tip tubes until you adapt to the change and are sure that you are not at risk to tip over.



WARNING! Ensure the ball detents on the quick-release axles snap into place and are fully visible after drive wheel installation

IV. COMFORT ADJUSTMENTS

To change the drive wheel position:

1. Press the quick-release button and pull the drive wheel off. **See figure 13.**
2. Remove the hardware that fastens the drive wheel bracket to the frame. **See figure 14.**
3. Reposition the drive wheel bracket to the desired position (either A or B).
4. Reinstall the hardware that fastens the drive wheel bracket to the frame.
5. Reinstall the drive wheel. Make sure that the wheel axle is snapped securely into the axle bracket.

NOTE: Make sure that both drive wheels are adjusted to the same position.

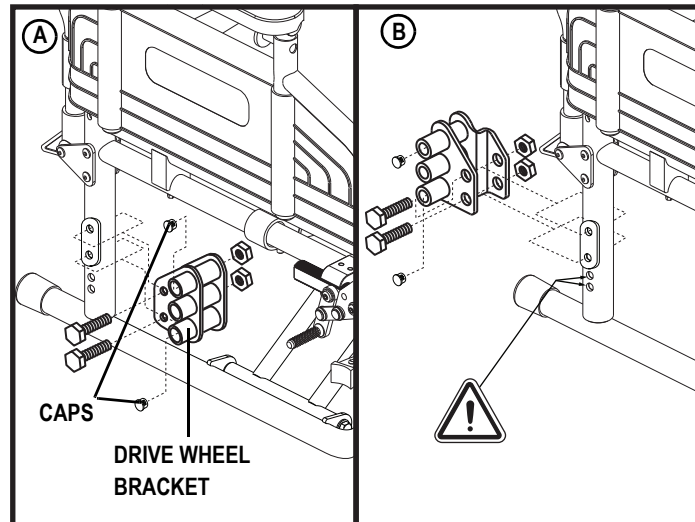

Figure 14. Drive Wheel Position Adjustment



WARNING! If your wheelchair is equipped with a transit securement system, the drive wheel height should only be adjusted by a Quantum Rehab Provider or a qualified technician.

NOTE: If the caps are removed to obtain the desired center of gravity, make sure that they are replaced in the same hole on each side of the wheelchair to maintain the same STF height on each side.

To change the drive wheel height:

1. Press the quick-release button and pull the drive wheel off. **See figure 13.**
2. Remove the caps from the unused positions in the drive wheel bracket by inserting a screwdriver into the uncapped end and pushing the cap out.
3. Reposition the drive wheel up or down to the desired position.

NOTE: The wheel height can be adjusted to 3 different positions. See figure 15A and 15B for more information on seat-to-floor heights.

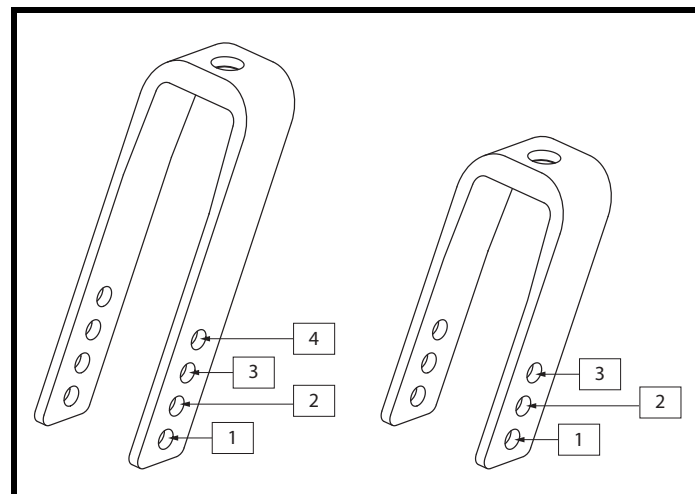

Figure 15. Long and Short Caster Fork Positions

4. Insert the caps into the unused positions in the drive wheel bracket.

NOTE: Make sure that the caps on both sides of the wheelchair are inserted into the same positions on the drive wheel bracket. This will ensure that both drive wheels are adjusted to the same height.

5. Reinstall the drive wheel. Make sure that the wheel axle is snapped securely into the axle bracket or the hardware is reinstalled and securely tightened, depending on drive wheel.

NOTE: Make sure that both drive wheels are adjusted to the same position.



WARNING! Ensure the quick-release axles are properly secured.

IV. COMFORT ADJUSTMENTS

Front Seat-to-Floor Height Matrix (Caster Wheel)

| STF Height | 10.16 cm (4 in.) | 12.7 cm (5 in.) | 15.24 cm (6 in.) | 20.32 cm (8 in.) |
|---------------------|---------------------|--------------------|---------------------|---------------------|
| 30.48 cm (12 in.) | S3 | | | |
| 31.75 cm (12.5 in.) | S2 | | | |
| 33.02 cm (13 in.) | S1/F3 | S2 | | |
| 34.29 cm (13.5 in.) | T3/F2 | S1/T4 | | |
| 35.56 cm (14 in.) | T2/F1 | T3/F2 | *S1/T4 | |
| 36.83 cm (14.5 in.) | T1 | T2/F1 | T3 | |
| 38.1 cm (15 in.) | | T1 | T2/F1 | |
| 39.37 cm (15.5 in.) | | | T1 | |
| 40.64 cm (16 in.) | | | | T2 |
| 41.91 cm (16.5 in.) | | | | T1 |
| 44.45 cm (17.5 in.) | | | T1/E | |
| 45.72 cm (18 in.) | | | | T2/E |
| 47 cm (18.5 in.) | | | | T1/E |

S = Short Fork
 T = Tall Fork
 F = Frog Legs
 E = 5 cm (2 in.) extension

*Not available with quick-release fork option. All measurements are +/- 0.25 in. (0.6 cm).

Figure 15A. Front Seat-to-Floor Height Matrices

Rear Seat-to-Floor Height Matrix (Drive Wheel)

| Wheel: | 50.8 cm (20 in.) | 50.8 cm (20 in.) Flipped | 55.88 cm (22 in.) | 55.88 cm (22 in.) Flipped | 60.96 cm (24 in.) | 60.96 cm (24 in.) Flipped |
|----------------------|---------------------|--------------------------------|----------------------|---------------------------------|----------------------|---------------------------------|
| STF | | | | | | |
| 30.48 cm (12 in.) | T | | | | | |
| 33.02 cm (13 in.) | M | T | T | | | |
| 35.56 cm (14 in.) | B | M | M | T | T | |
| 38.1 cm (15 in.) | | B | B | M | M | T |
| 40.64 cm (16 in.) | | | | B | B | M |

Figure 15B. Rear Seat-to-Floor Height Matrices

*STF height may vary +/- 0.25 in. (0.6 cm) depending on wheel type.

T = Top hole of mounting bracket
 M = Middle hole of mounting bracket
 B = Bottom hole of mounting bracket

IV. COMFORT ADJUSTMENTS

Swing-Away Footrest (SFR) Removal

The Swing-away Footrests (SFR) can be moved or removed to aid in transfers or transporting your wheelchair.

To move the SFR to the side:

1. Push the release lever back. See figure 16.
2. Move the SFR aside.
3. Repeat for the other side if necessary.

To remove the SFR:

1. Ensure the SFR is facing forward and not swung to the side.
2. Push the release lever back.
3. Pull the SFR up. See figure 17.
4. Repeat for the other side if necessary.

Swing-Away Footrest (SFR) Foot Plate Length

You can change the SFR foot plate length between 26-33 cm (10.25-13 in.) in 1.91-cm (0.75-in.) increments. This length is measured from the SFR foot plate to the top of the SFR. See figure 18.

To change the SFR foot plate length:

1. Remove the screws from the SFR.
2. Adjust the foot plate to the desired length.
3. Reinstall the screws into the SFR.
4. Repeat for the other side.

Elevating Leg Rest (ELR) Foot Plate Length

You can change the ELR foot plate length between 33.66-55.88 cm (13.25-22 in.). This length is measured from the ELR foot plate to the top of the ELR. See figure 19.

To change the ELR foot plate length:

1. Loosen the screws on the back of the ELR.
2. Adjust the foot plate to the desired length.
3. Tighten the screws on the back of the ELR.
4. Repeat the procedure for the other side.

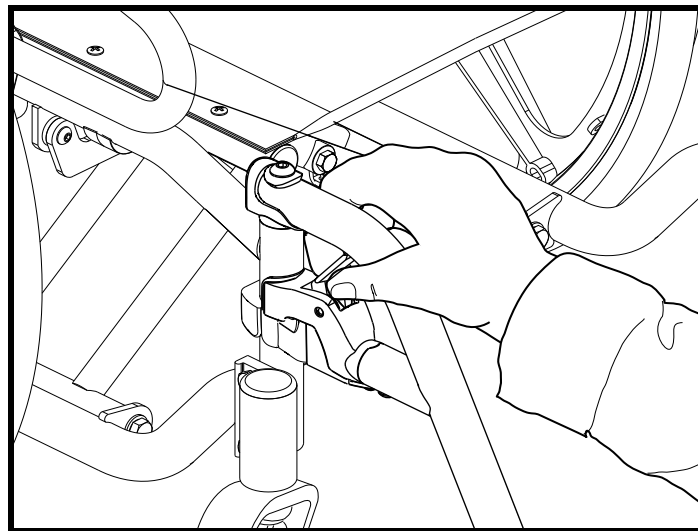

Figure 16. SFR Release

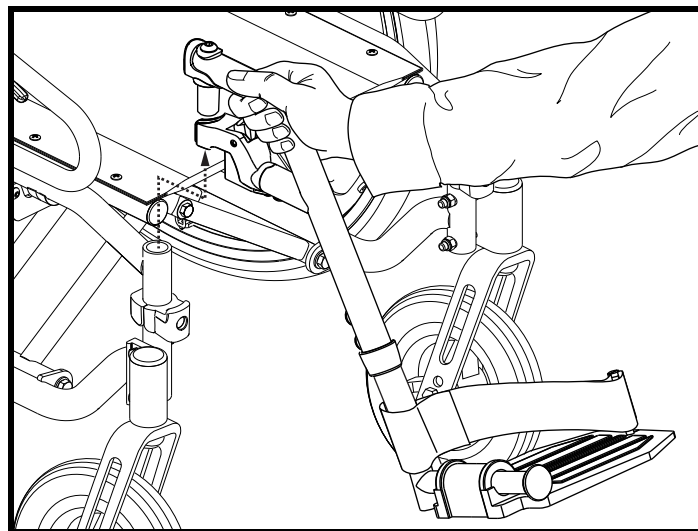

Figure 17. SFR Removal

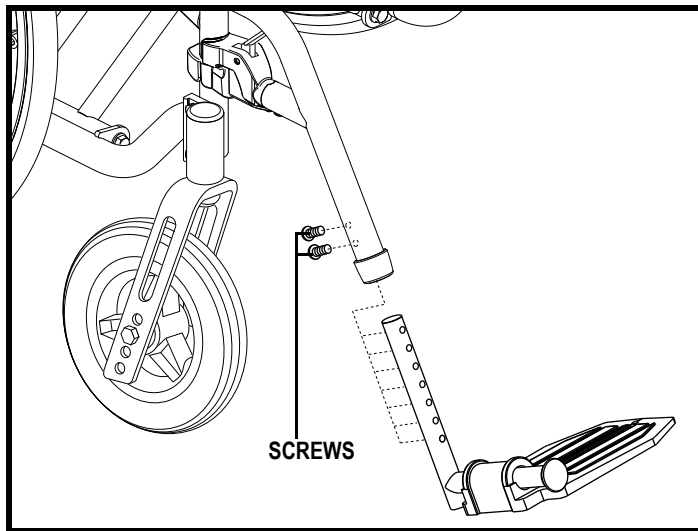

Figure 18. SFR Foot Plate Adjustment

IV. COMFORT ADJUSTMENTS

ELR Angle Adjustment

You can change the ELR angle. See figure 20.

To change the ELR angle:

- 1 To raise, pull the ELR up to the desired position.
- 2 To lower, pull the ELR release lever and lower the ELR to the desired position.



WARNING! Use care when operating. Possible pinch point created during operation.

ELR Calf Pad Adjustment

You can change the height and depth of the ELR calf pad. See figures 21 and 22.

To change the ELR calf pad height:

1. Remove the screw to unfasten the calf pad from the ELR.
2. Move the calf pad up or down to the desired position.
3. Replace the screw to refasten the calf pad to the ELR.
4. Repeat for the other side.

To change the ELR calf pad depth:

1. Remove the screw to unfasten the calf pad from the calf pad bracket.
2. Move the calf pad in or out to the desired position.
3. Replace the screw to refasten the calf pad to the calf pad bracket.
4. Repeat for the other side.

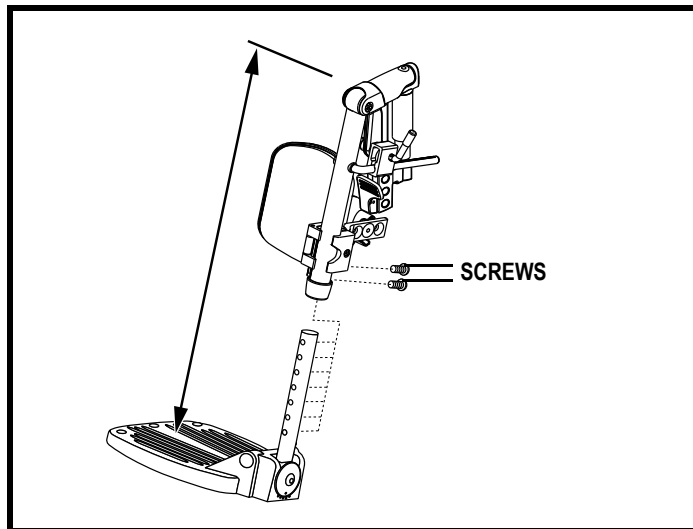

Figure 19. ELR Foot Plate Adjustment

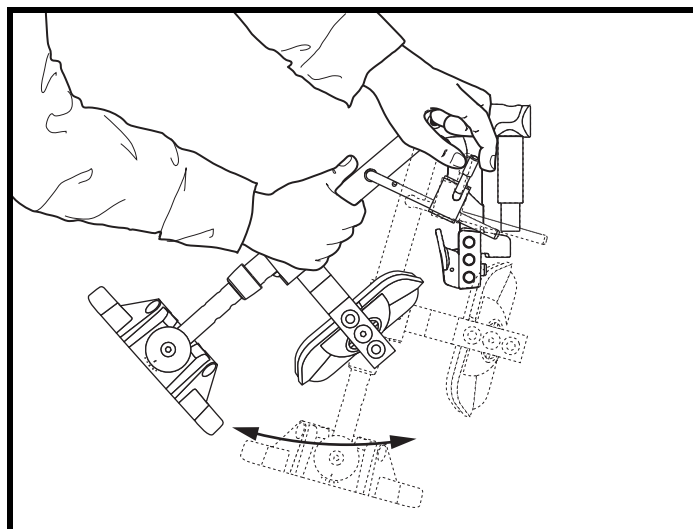

Figure 20. ELR Angle Adjustment

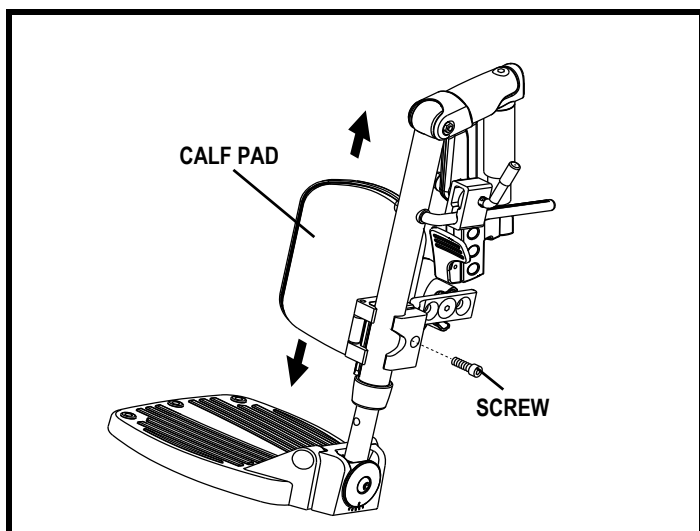

Figure 21. ELR Calf Pad Height Adjustment

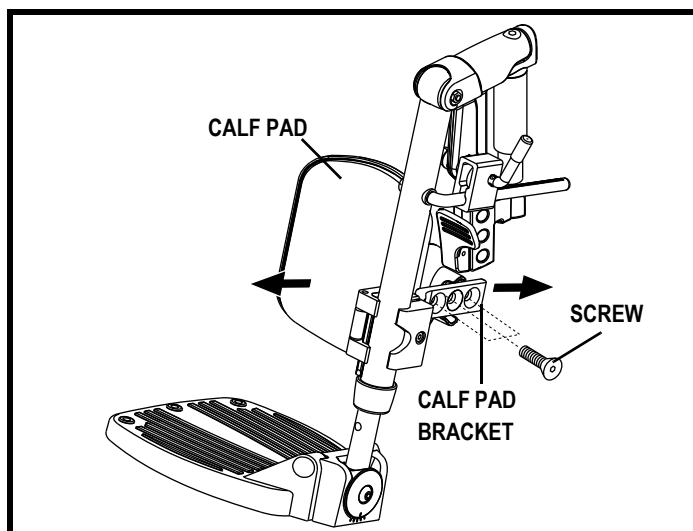

Figure 22. ELR Calf Pad Depth Adjustment

IV. COMFORT ADJUSTMENTS

Angle Adjustable Foot Plates

The angle adjustable foot plates have two adjustments: angle and depth. The depth can be adjusted to four (4) positions in 2.5 cm (1-in.) increments. If the position of the foot plate adapter is reversed, an additional 2 cm (0.75 in.) of depth can be achieved at the most forward and most rearward positions. See **figure 25**. The foot plates can also be flipped up for ease of transfer. See **figure 23**.

To adjust the foot plate angle:

1. Loosen the screws in the foot plate.
2. Tilt the foot plate forward or back to the desired angle. See **figure 24**.
3. Tighten the screws to secure the foot plate in place.

To adjust the foot plate depth:

1. Remove the screws and nuts from the foot plate assembly. See **figure 25**.
2. Remove the foot plate and foot plate adapter from the leg rest extension.
3. Reposition the foot plate on the foot plate adapter to achieve the desired depth. See **figure 25**.
4. Reinstall the screws to the foot plate and secure with the nuts. Do not fully tighten.
5. Slide the foot plate assembly onto the leg rest extension.
6. Adjust the foot plate to the desired angle and fully tighten the screws.

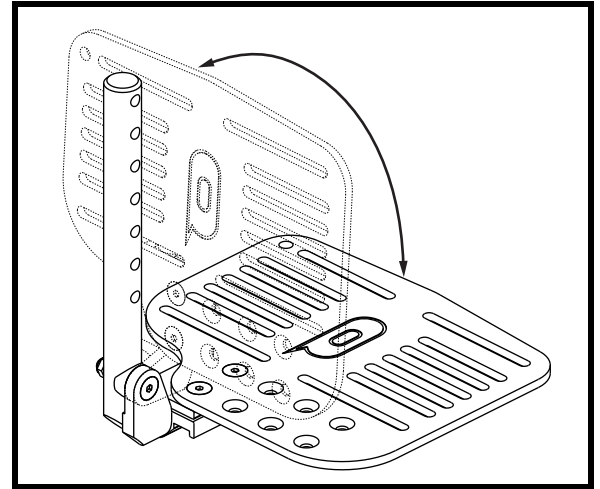

Figure 23. Foot Plate Flip Up Adjustment

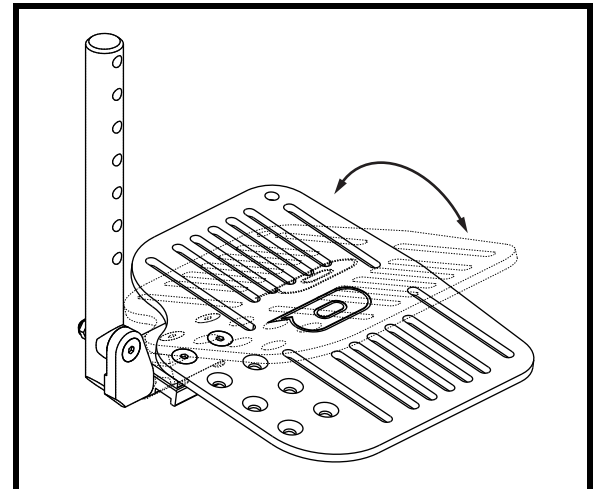

Figure 24. Foot Plate Angle Adjustment

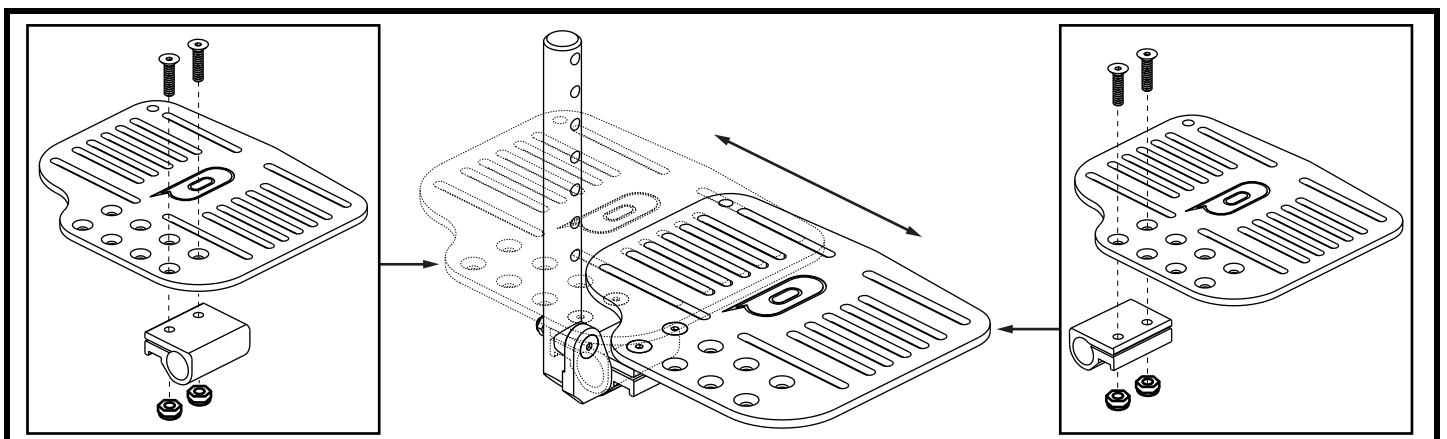

Figure 25. Foot Plate Depth Adjustment

IV. COMFORT ADJUSTMENTS

Seatback Height

You can adjust the seatback to one of two different heights. The adjustment range is 5 cm (2 in.) in 2.5-cm (1-in.) increments. See figure 26.

To adjust the seatback height:

1. Remove the screws and nuts that fasten the seat canes to each side of the frame.
2. Slide the seat canes up or down to the desired height.
3. Use the screws and nuts to refasten the seat canes to the frame.

Seatback Angle Adjustment (Optional)

Your wheelchair may be equipped with angle adjustable back canes that allow you to adjust the seatback to one of five different angles. The angle adjustment range is 85°-105° in 5° increments. See figure 27.

To adjust the seatback angle:

1. Remove the top screw and nut from the back cane and loosen the lower screw. See figure 26.
2. Rotate the eccentric washer to the appropriate position that represents the desired angle. See figure 27.
3. Reinstall the hardware to its original position from step 1.

Seat Angle (Dump) Adjustment

The position of the caster wheels affects the angle (dump) of the seat. By changing the location of the caster wheel on the fork, you change the seat angle. See figure 32.

NOTE: You can also adjust the seat angle by raising or lowering the drive wheel. See "Drive Wheel Position."

To change the seat angle:

1. Remove the hardware that fastens the caster wheel to the caster fork.
2. Reposition the caster wheel on the caster fork.
3. Reinstall the hardware that fastens the caster wheel to the caster fork.
4. Repeat the procedure for the other side, making sure both caster wheels are adjusted to the same position.



WARNING! Changing the seat angle may adversely affect stability and cause the wheelchair to tip over.

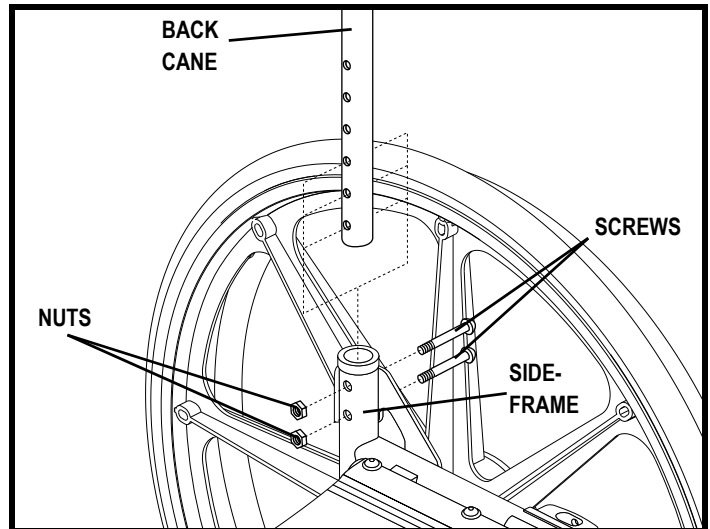

Figure 26. Seatback Height Adjustment

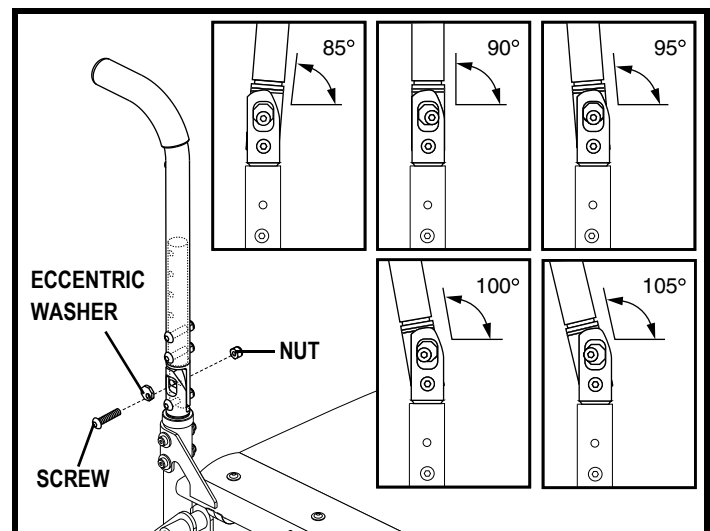

Figure 27. Seatback Angle Adjustment

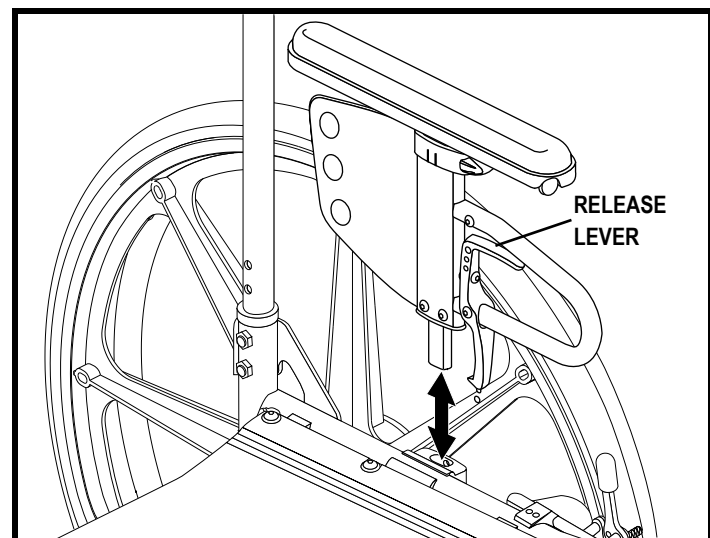

Figure 28. Single-post Armrest Removal

IV. COMFORT ADJUSTMENTS

Armrest Removal

The armrests can be removed to aid in transfers or transporting your wheelchair.

To remove the armrest:

1. Squeeze the release lever. See figure 28.
2. Pull the armrest up.
3. Repeat for the other side if necessary.



WARNING! Use care when operating. Possible pinch point created during operation.

Armrest Height Adjustment

You can adjust the armrest height to seven positions in 2.54-cm (1-in.) increments.

To adjust the armrest:

1. Rotate the latch located on the armrest. See figure 29.
2. Move the armrest up or down to the desired height.
3. Release the latch.
4. Make sure the armrest locks into place.
5. Repeat for the other side if necessary.

Dual-post Armrests

The dual-post armrests can be adjusted to aid in transfers or transporting your wheelchair.

To flip the dual-post armrest back:

1. Pull back the armrest latch located on the armrest. See figure 30.
2. Flip the armrest back.
3. Repeat the procedure for the other side if necessary.

To adjust the dual-post armrest height:

1. Pull back the release lever that is located on the armrest in either direction. See figure 31.
2. Move the armrest up or down to the desired height.
3. The release lever is spring-loaded and will automatically release.
4. Make sure the armrest latches into place.
5. Repeat the procedure for the other side if necessary.

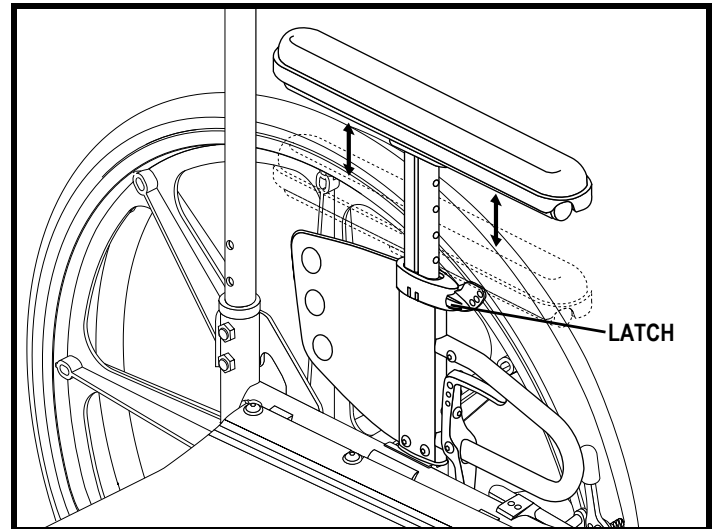

Figure 29. Single-post Armrest Height Adjustment

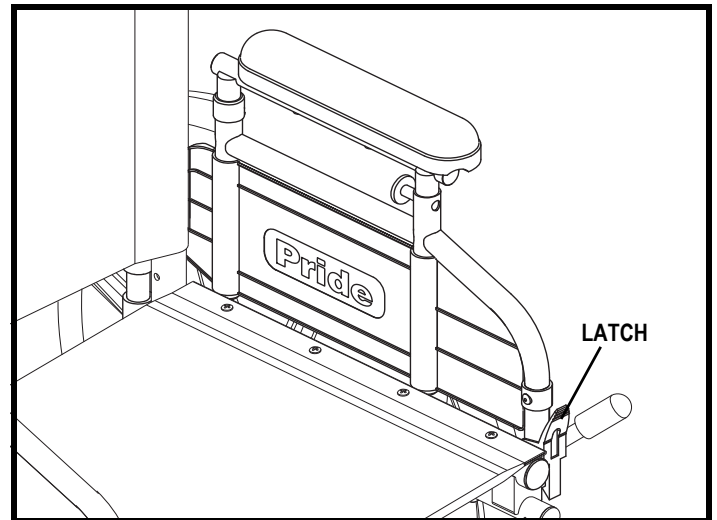

Figure 30. Dual-post Armrest Removal

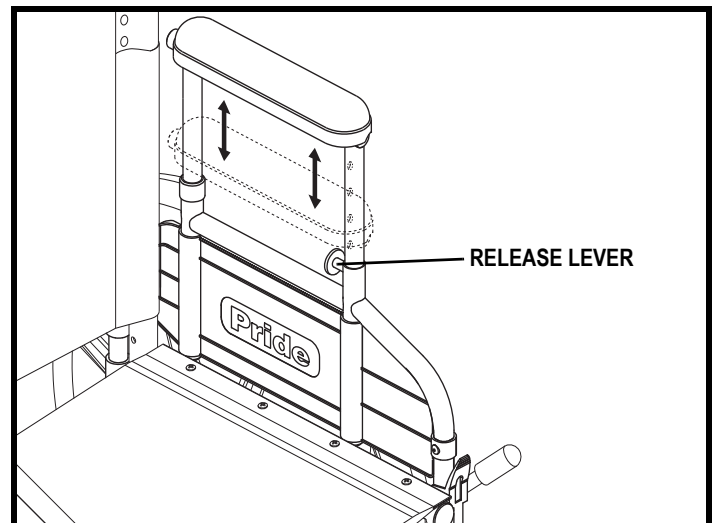

Figure 31. Dual-post Armrest Height Adjustment

IV. COMFORT ADJUSTMENTS

Caster Angle Adjustment

When you change the seat angle, you must also change the caster angle so that the caster barrels remain at a 90° angle to the ground. There are seven possible caster angles. See figure 33.

NOTE: There are two screws that fasten the caster barrel assembly to the frame. The nuts that secure the screws are eccentric. The eccentric nuts should be positioned to the appropriate setting for the desired angle. A right-angle square is recommended for aligning the caster barrels to ensure 90° alignment to the ground.

To change the caster angle:

1. Remove the screws that fasten the caster wheel assembly to the frame.
2. Reposition the eccentric nuts to the desired setting and reinsert the bolts.
3. Tighten the screws.

NOTE: Either apply thread lock or obtain new hardware when reinstalling the caster wheels.

NOTE: Make sure that both casters are adjusted to the same angle.

Caster Wheel Removal

The casters can be removed one of two ways, depending on caster style.

To remove the bolt-on caster wheel:

1. Remove the hardware that attaches the caster wheel to the frame of your wheelchair. See figure 34.
2. Repeat for the other side if necessary.

To remove the quick-release caster wheel:

1. Press the quick-release button and pull the caster wheel off. See figure 34.
2. Repeat for the other side if necessary.

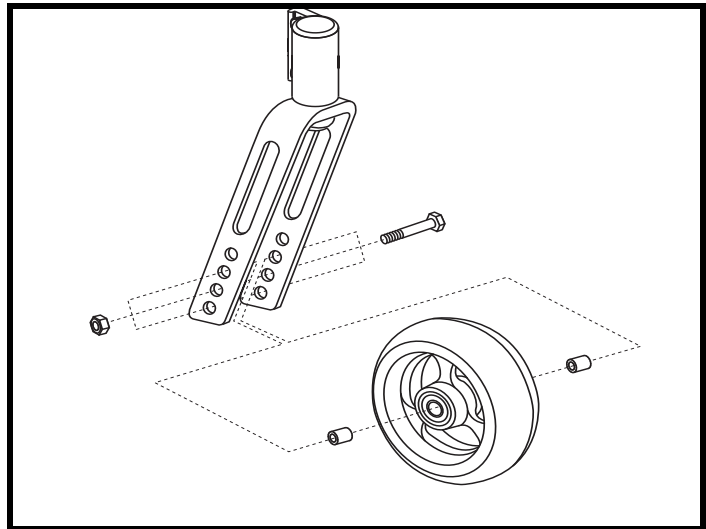

Figure 32. Caster Wheel Position

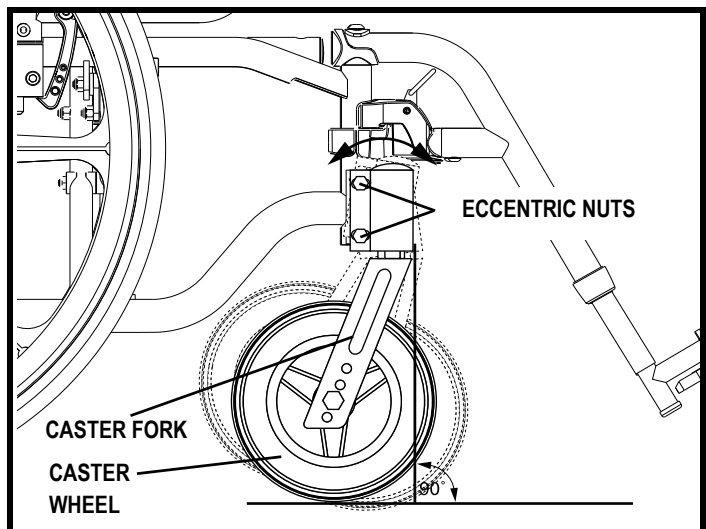

Figure 33. Caster Angle Adjustment

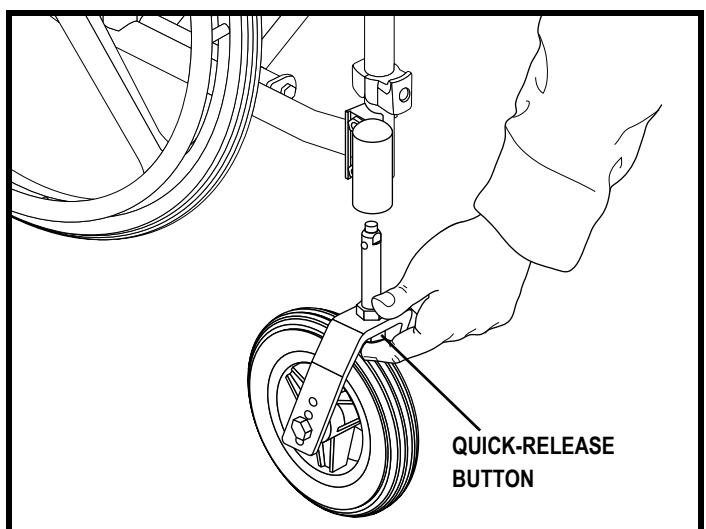

Figure 34. Quick-release Caster Removal

IV. COMFORT ADJUSTMENTS

Positioning Belt

Your wheelchair may be equipped with a positioning belt that can be adjusted for operator comfort. See figure 35. The positioning belt is designed to support the operator so that he/she does not slide down or forward in the seat. The positioning belt is not designed for use as a restraining device in a motor vehicle.



WARNING! The positioning belt should be secured at all times. Never allow the positioning belt to hang or drag on the floor as it may become entangled.

To install the positioning belt:

1. Remove the screws on both the left and right seat canes. See figure 35.
2. Insert the screws that were removed in step 1 through the bracket and then through the seat canes on each side of the wheelchair seat. See figure 35.
3. Tighten both screws.
4. Install the positioning belt onto the bracket and pull until the positioning belt snaps into place.

To adjust the positioning belt for operator comfort:

1. Once seated, insert the metal tab on one side of the belt into the plastic housing on the opposite side until you hear a click. See figure 36.
2. Pull the excess strap attached to the metal tab until it is secure, but not so tight as to cause discomfort.

To release the positioning belt:

1. Push the button mechanism on the plastic housing.

MANDATORY! Make sure the positioning belt is properly secured to the wheelchair and is adjusted for operator comfort before each use.



MANDATORY! Inspect the positioning belt for loose or damaged parts before each use of the wheelchair. If you discover a problem, contact your Quantum Rehab Provider for maintenance and repair.

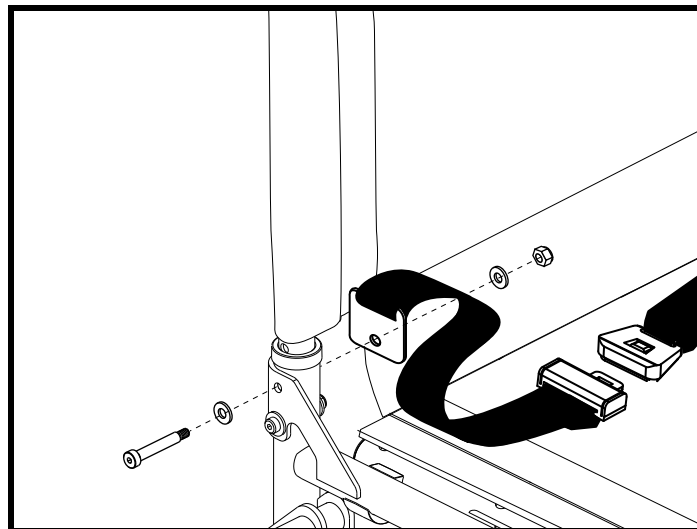

Figure 35. Positioning Belt Installation

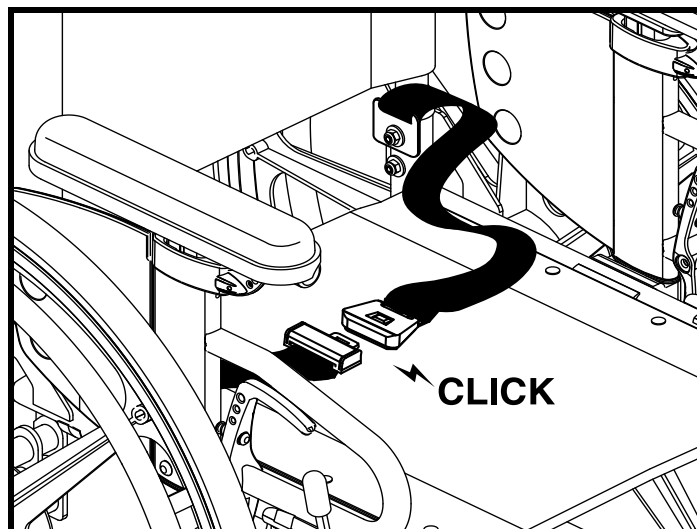

Figure 36. Positioning Belt Adjustment

IV. COMFORT ADJUSTMENTS

Anti-tip Wheel Adjustment

Anti-tip wheels are an integral and important safety feature of your wheelchair. They are factory set to between 0.75-2 in. (2-5 cm), but may require adjustment to accommodate depth adjustment and center of gravity.



PROHIBITED! Do not remove the anti-tip wheels or modify the wheelchair in any way that is not authorized by Pride.



WARNING! The anti-tip wheels should only be adjusted by a Quantum Rehab Provider or a qualified technician.

To adjust the anti-tip wheels:

1. Remove the detent pin from the anti-tip wheel. See **figure 37**.
2. Adjust the anti-tip wheel to the desired position while aligning the anti-tip wheel with the adjustment holes.
3. Once properly positioned, reinsert the detent pin and ensure that it is fully engaged.
4. After installing or adjusting the anti-tip wheels, push and pull on both anti-tip wheels to ensure they are properly engaged.
5. Repeat for the other side.

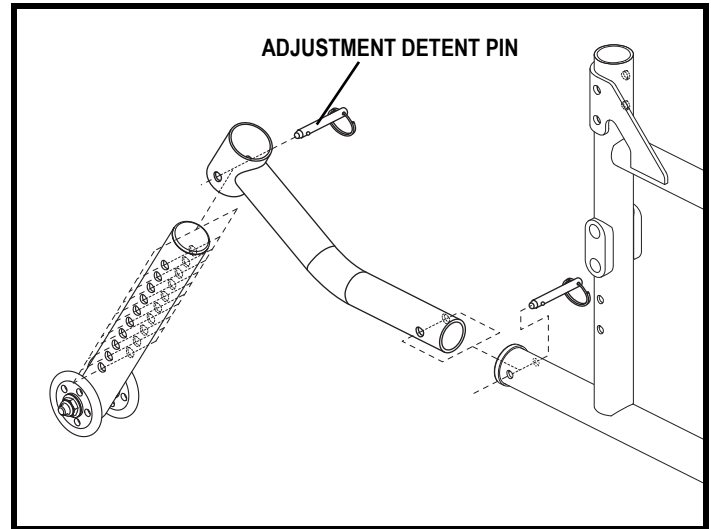

Figure 37. Anti-tip Wheel Adjustment

V. CARE AND MAINTENANCE

CARE AND MAINTENANCE

Your Litestream XF LTD RQ requires routine maintenance checks. You can perform some of these checks, but others require assistance from your Quantum Rehab Provider. Preventive maintenance is very important. If you follow the maintenance checks in this section as scheduled, you can help ensure that your wheelchair gives you years of trouble-free operation. If you have any doubt as to your wheelchair's care or operation, contact your Quantum Rehab Provider.



WARNING! Do not service the wheelchair when the seat is occupied.

Your wheelchair is susceptible to damage from the elements. Avoid damp areas of any kind.



WARNING! Direct or prolonged exposure to water or dampness could cause the wheelchair to malfunction mechanically. Water can cause the chair's frame to rust. Wheelchairs should be examined periodically for signs of corrosion caused by water exposure, bodily fluids exposure, or incontinence. Damaged components should be replaced or treated immediately.

Should your wheelchair come in contact with water:

1. Dry your wheelchair as thoroughly as possible with a towel.
2. Allow your wheelchair to sit in a warm, dry place for 12 hours to allow unseen water to evaporate.
3. If any inconsistencies are found, take your wheelchair to your Quantum Rehab Provider. Wheelchairs that are frequently exposed to sources of water, such as incontinence, should be inspected often for corrosion.

Temperature

Some of the parts of your wheelchair are susceptible to extreme changes in temperature. Always keep your wheelchair between the temperatures of -8°C (18°F) and 50°C (122°F).

General Guidelines

- Avoid prolonged exposure of your wheelchair to extreme conditions, such as heat, cold, or moisture.
- Make sure the pneumatic tires are inflated to the psi/bar/kPa air pressure rating indicated on the tire if equipped with pneumatic tires.



WARNING! Make sure your tires are inflated to the psi/bar/kPa air pressure rating indicated on the tire. Do not underinflate or overinflate your tires. Low pressure may result in loss of control, and overinflated tires may burst. Overinflating tires can cause them to explode.

WARNING! Do not use a high pressure hose to inflate your tires.

- Use a rubber conditioner on the tire sidewalls to help preserve them.



WARNING! Never use a rubber conditioner on the tread area of the tires; doing so may make the tires slippery and cause your wheelchair to skid.

- All wheel bearings are prelubricated and sealed. They require no subsequent lubrication.

Daily Checks

- Check the seat for any visible damage.
- Check for loose or missing screws, nuts, and bolts. Replace or tighten them as necessary.
- Check the tires. Look for uneven wear, holes, or tire/rim separation. If they look excessively worn, then have them replaced.
- Visually inspect pneumatic tires for punctures.
- Confirm correct air pressure as marked on the side of the tire.
- Check for flat spots on solid tires. Flat spots could adversely affect stability.

V. CARE AND MAINTENANCE

- Confirm that the strap used to fold down the seatback is not torn or frayed.
- Check the handrims. Make sure that they are fastened securely to the wheels.
- Check the wheel locks. Make sure they work properly. If they do not, instructions on how to adjust them are provided in this manual.



WARNING! The manual wheel locks are designed to keep your chair stationary while you are parked. They are not designed to stop the wheelchair during driving. Do not use either of the manual wheel locks to stop the wheelchair while driving it. This can cause your wheelchair to become unstable and tip.

Weekly Checks

- Check for proper tire inflation. Pneumatic tires should be inflated to the psi/bar/kPa air pressure rating indicated on the tire. If a tire does not hold air, see your Quantum Rehab Provider for replacement of the tube.
- Check the anti-tip wheels for wear or damage. See your Quantum Rehab Provider for replacement or repair.

Monthly Checks

- Check for drive tire wear. See your Quantum Rehab Provider for repair.
- Check the caster wheels for wear. Replace them as necessary.
- Check the caster forks for damage or fluttering which indicates that they may need to be adjusted or have the bearings replaced. See your Quantum Rehab Provider for repair.
- Keep your wheelchair clean and free of foreign material, such as mud, dirt, hair, food, drink, etc.

Yearly Checks

Take your wheelchair to your Quantum Rehab Provider for yearly maintenance, especially if you use your wheelchair on a daily basis. This helps ensure that your wheelchair is functioning properly and helps prevent future complications.

Storage

Your wheelchair should be stored in a dry place, free from temperature extremes.



WARNING! If you fail to store the unit properly, the frame can rust.

You may wish to place several boards under the frame of your wheelchair to raise it off of the ground during periods of prolonged storage. This takes the weight off the tires and reduces the possibility of flat spots developing on the areas of the tires contacting the ground.

Disposal of Your Wheelchair

Your wheelchair must be disposed of according to applicable local and national statutory regulations. Contact your local waste disposal agency or Quantum Rehab Provider for information on proper disposal of wheelchair packaging, metal frame components, plastic components, neoprene, silicone, and polyurethane materials.

Cleaning and Disinfection

- Use a damp cloth and mild, non-abrasive cleanser to clean the plastic and metal parts of your wheelchair. Avoid using products that may scratch the surface of your wheelchair.
- If necessary, clean your product with an approved disinfectant. Make sure the disinfectant is safe for use on your product before application.



WARNING! Follow all safety instructions for the proper use of the disinfectant and/or cleaning agent before applying it to your product. Failure to comply may result in skin irritation or premature deterioration of upholstery and/or wheelchair finishes.

WARNING! Never hose off your wheelchair or place it in direct contact with water. Your wheelchair has a painted finish that allows it to be easily wiped clean with a damp cloth.

V. CARE AND MAINTENANCE



WARNING! Never use any chemicals to clean a vinyl seat, as they may cause the seat to become slippery or dry out and crack. Use soapy water and dry the seat thoroughly.

Wheel Replacement

If you have pneumatic tires and you have a flat tire, you can replace the tube. If your wheelchair is equipped with a solid tire insert, then you must replace the entire wheel assembly. Replacement tires, tubes, and wheel assemblies are readily available through your Quantum Rehab Provider.



WARNING! The wheels on your wheelchair should only be serviced or replaced by a Quantum Rehab Provider or a qualified technician.

WARNING! When changing a tire, remove the entire drive wheel. If any further disassembly is required, deflate the tire completely or it may explode.

To replace a pneumatic tire tube:

1. Remove the drive wheel from the frame. See figure 13.
2. Make sure that the tube is deflated completely.
3. Use several tire levers to pry the tire from the rim. Tire levers are available from a bicycle shop.
4. Remove the old tube.
5. Inflate the new tube with enough air so that it just starts to take shape.
6. Insert the tube into the tire.
7. Use the tire levers to secure the tire back onto the rim.
8. Inflate the tire to the psi/bar/kPa air pressure recommended on the sidewall. Always use a regulated air source.
9. Reinstall the drive wheel to the frame. Make sure that the wheel axle is snapped securely into the frame bracket.

Manual Wheel Locks

After several months of use, you may find it necessary to adjust the wheel locks so that they lock securely when engaged. You also may need to adjust them after changing the drive wheel position.



WARNING! If your wheelchair is equipped with pneumatic tires, make sure they are inflated to the pressure recommended on the sidewall of the tire.

To adjust each manual wheel lock:

1. Disengage the wheel lock. See figure 6. The wheel lock blade should be 0.64 cm (0.25 in.) away from the tire for both pneumatic and solid tires.
2. Loosen the hardware that fastens the wheel lock to the frame. See figure 38.
3. Reposition the wheel lock so that the blade is 0.25 in. (0.64 cm) away from the tire and perpendicular to the plane of the tire.
4. Tighten the hardware that fastens the wheel lock to the frame.
5. Engage the wheel lock and note the position of the blade.
6. Reposition the wheel lock if necessary.
7. Repeat the procedure for the other side.

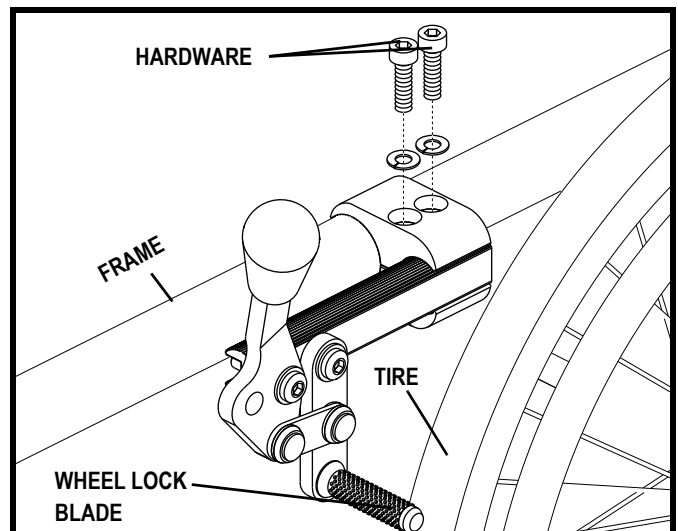

Figure 38. Wheel Lock Adjustment

V. CARE AND MAINTENANCE

Seat Tension

After a period of use, you may find it necessary to adjust the seat tension.

To adjust the seat tension:

1. Loosen the screws that attach the seat to the side rail on the left side (side with hook and loop fastener). See figure 39.
2. Unfasten the hook and loop fastener.
3. Grab the bottom flap and pull the seat tight.
4. Fasten the hook and loop fastener.
5. Tighten the screws. Make sure that the plastic washers are on top of the fabric.

When to See Your Quantum Rehab Provider for Service

The following symptoms could indicate a serious problem with your wheelchair. If necessary, contact your Quantum Rehab Provider. When calling, have the model number, serial number, and nature of the problem.

- Uneven wear on any of the tires
- Bent or broken wheel assemblies
- Loose or missing hardware that attaches the transit securement brackets or positioning belt anchors to the wheelchair.

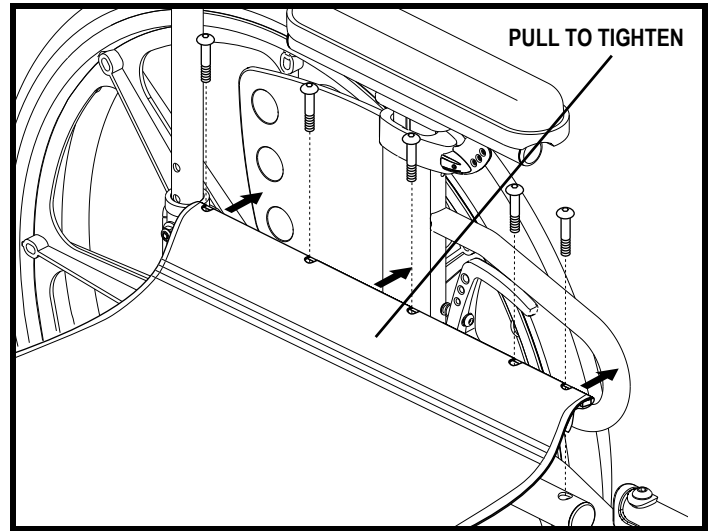

Figure 39. Seat Tension Adjustment

VI. WARRANTY

LIFETIME LIMITED WARRANTY

Pride offers a **lifetime warranty** from the date of possession of the original wheelchair to repair or replace any of the following parts found upon examination by an authorized representative of Pride to be defective: **cross frame and side frames**. (Including labor for one year, excluding armrests, front riggings, positioning belt, and armrest fixtures.)

ONE YEAR LIMITED WARRANTY

Pride warrants for a period of **one (1) year** from the date of possession of the original wheelchair to repair or replace any of the following parts found upon examination by an authorized representative of Pride to be defective: **basic components and optional components** (including labor).

TWELVE MONTH LIMITED WARRANTY

Pride warrants for a period of **twelve (12) months** from the date of replacement to repair or replace any of the following parts found upon examination by an authorized representative of Pride to be defective: **basic components, optional components, and new parts replaced by the provider or retailer** (including labor) with the exception of tires, tubes, arm pads, bearings, seat slings, and back slings which are covered by a **thirty (30) day** warranty.

THIRTY DAY LIMITED WARRANTY

Pride warrants for a period of **thirty (30) days** from the date of possession of the original wheelchair to repair or replace any of the following parts found upon examination by an authorized representative of Pride to be defective: **tires, tubes, arm pads, bearings, seat slings, and back slings** (including labor).

WARRANTY EXCLUSIONS

- Paint is subject to normal wear and tear and is not covered under warranty.
- Repairs and/or modifications made to any part without specific consent from Pride.
- Circumstances beyond the control of Pride Mobility Products.
- Any damage caused by:
 - Abuse, misuse, accident, or negligence.
 - Improper operation, maintenance, or storage.
 - Commerical use, or use other than normal.
- There is no other express warranty.

Implied warranties, including those of merchantability and fitness for a particular purpose, are limited to one (1) year from the date of the original purchase and to the extent permitted by law. Aside from the warranty presented in the above, Pride will not be held responsible for any and all other consequential, direct, or indirect damages, foreseeable or unforeseeable in nature, for the loss of the free use or waste of time resulting from the use of this vehicle. Pride Mobility Products offers no warranty regarding the wear and use of this type of vehicle.

Some states and certain provinces do not allow limitations on how long an implied warranty lasts or do not allow the exclusion or limitation of incidental or consequential damages. This warranty gives you specific rights, and you may also have other rights which vary from province to province.

NOTES

Quality Control - Lifestream XF LTD RQ

Inclusion of all Parts

Fit and Finish

Performance



Pride keeps a more detailed report on file at the factory.

Date Inspected

Inspector

*** I NFMANU4240***

Product Serial #